

DRINKING FOUNTAIN: G20100N

G20100N | 2000100146

ARTICLE GROUP : **G20100N** | ARTICLE FAMILY : **Drinking fountains unchilled** | PRODUCT GROUP : **Water dispensers**

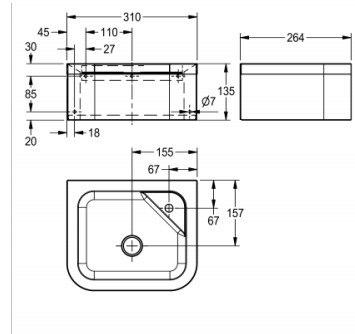

Drinking water fountains are manufactured from grade austenitic stainless steel, material thickness 1.2mm, supplied complete with 19mm waste and water bubbler. The wall mounted model is simply fixed to the wall using a joggle strip and integral mounting brackets.

TECHNICAL DATA

Bowl height	135.00 mm
Bowl width	310.00 mm
Bowl depth	264.00 mm
Gross weight	3.20 kg
Material	Stainless steel
Material code	1.4301 Chrome Nickel steel V2A
Material thickness	1.20 mm
Overall depth	135.00 mm
Overall height	264.00 mm
Overall width	310.00 mm
Surface finish	Satin finish
Type of mounting	Wall mounting
Type of operation	manual operation
Waste hole position	Centre
Waste hole projection	150.00 mm
Waste size	DN 20
Net weight	2.80 kg
Product code	213.0000.011