

CHILLER: ANMX311

ANMX311 | 2000101234

ARTICLE GROUP : ANMX311 | ARTICLE FAMILY : Drinking fountains chilled | PRODUCT GROUP : Water dispensers

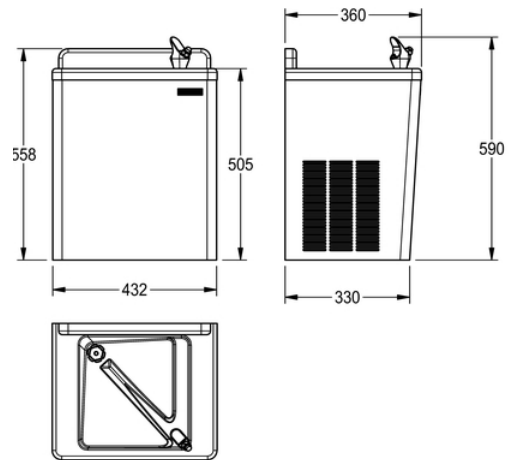

The range of Water Gem water coolers and drinking fountains from Franke Sissons offer a low maintenance and reliable solution where chilled drinking water is required in commercial buildings. Available as either floor standing or wall mounted and with or without a bottle filler, the products are connected direct to the water mains supply and supply an unlimited amount of chilled water which always has a fresh taste. The product requires 240V main electrical supply via a 3 pin plug socket. The coolers are made from durable coated steel panels and have an easy to open front panel for installation and maintenance. The key for the Water gem products is the same as for the Franke Rodan series of washroom accessories to simplify the number of keys needed for maintenance purposes. The products are provided with a chlorine based water filter as standard and this is recommended to be replaced every 6 months. Replacement filters are available from Franke Sissons.

With water filter

TECHNICAL DATA

drinking bubbler	yes
glass filler	no
gross weight	30.00 kg
material	stainless steel
material code	1.4301 Chrome Nickel steel V2A
material thickness	1.20 mm
net weight	30.00 kg
outlet size	DN 32
overall depth	360.00 mm
overall height	505.00 mm
overall width	432.00 mm
surface finish	satin finished
type of mounting	wall mounting
type of operation	manual operation